

### Series SL-V

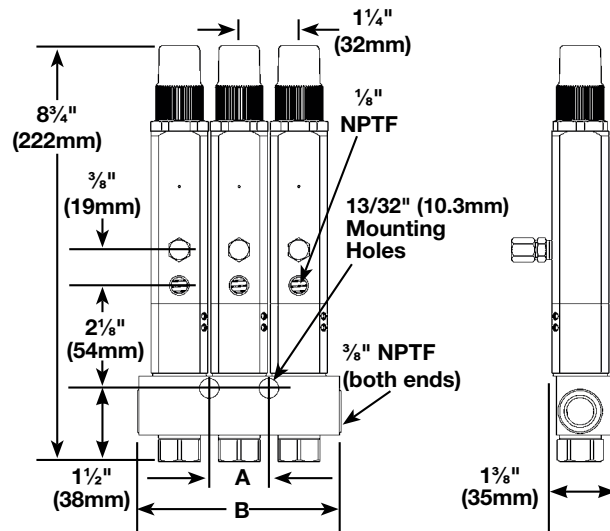

- For single-line, high-pressure central lubrication system.
- For dispensing lubricants compatible with polyurethane seals up to NLGI No. 2 (refer to Design Guide).
- Output is externally adjustable.
- Indicator stem permits visual check of injector operation.
- May be combined in a circuit of injectors SL-32, SL-33, SL-1, SL-V XL and/or SL-11.
- Individual injectors can be easily removed for inspection or replacement.
- Each SL-V injector includes a clear polycarbonate protective cap.

### Specifications:

Series	Material	Output		Operating Pressure				Connections	
		Min.	Max.	Min.	Max.	Typical	Vent	Manifold Inlet	Injector Outlet
SL-V	Carbon Steel	0.015 cu. in. 0.25 cc	0.08 cu. in. 1.31 cc	1850 psig 128 bar	6000 psig 413 bar	2500 psig 172 bar	1000 psig 60 bar	3/8" NPTF (F)	1/8" NPTF (F)

Model	Type	Number of Outlets	Dimension			
			A in.	A mm	B in.	B mm
85770-1	One Injector Manifold	1	Single Mounting Hole		2 1/2	63
85770-2	Two Injector Manifold	2			3	76
85770-3	Three Injector Manifold	3	1 1/4	32	4 1/4	108
85770-4	Four Injector Manifold	4	2	63	5 1/2	140
85770-5	Five Injector Manifold	5	3 3/4	95	6 3/4	171
85770-6	Six Injector Manifold	6	5	127	8	203
85771	Replacement for manifold injectors					
85772	Single injector/no manifold (3/8" NPTF(M) inlet)					

#### Notes:

1. Injector manifolds have 13/32" (10.3 mm) dia. mounting holes for 3/8" bolt.
2. Injectors have polyurethane seals. Check compatibility with synthetic lubricants.
3. Injector rated for 180°F (80°C) max. ambient temperature, depending on lubricant used.
4. Injectors include fitting for filling feedlines via alternate outlet port.
5. Output with adjustment screw hand-tightened is .015 cu. in. Maximum output is achieved with five turns at .014 cu. in./turn.